

NEENAH FOUNDRY CO. (PATTERN NO. R-1970) (PATTERN NO. R-1971) OR APPROVED EQUAL.

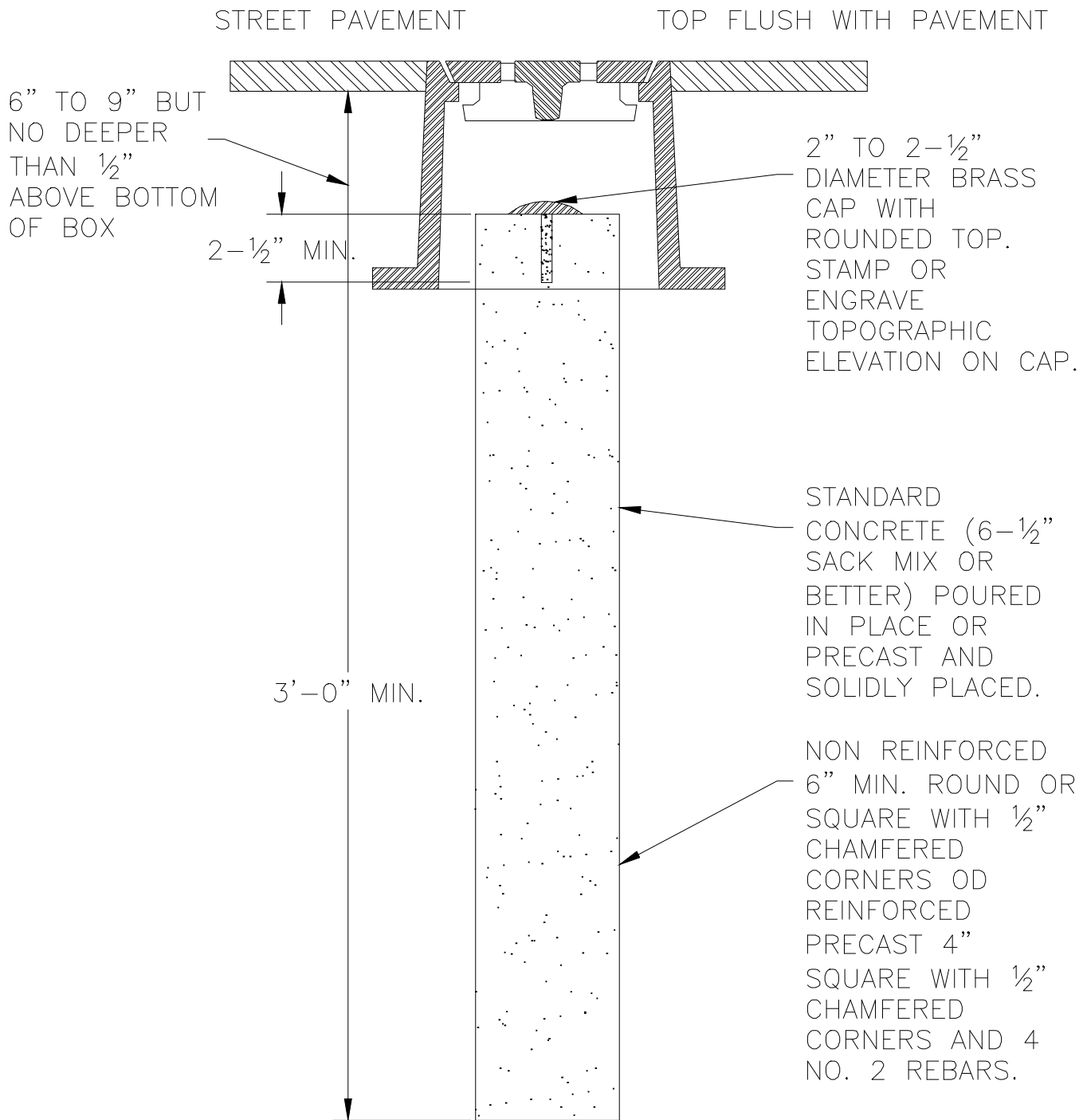

HORIZONTAL DATUM: NAD83 / WGS84 VERTICAL DATUM: NAVD88



THE CITY OF HARRISBURG
OFFICE OF THE CITY ENGINEER

PROJECT: MONUMENT AND BOX DETAIL

DRAWN BY: MICHAEL J. HILTON

DATE: SEPTEMBER 25, 1996

CHECKED BY: KRISTIE A. HEBERLIG

SCALE: NONE

SHEET:

D-23



**CITY OF HARRISBURG
OFFICE OF THE CITY ENGINEER
BENCHMARK DATA SHEET**

FORM D-23A

THIS FORM MUST BE COMPLETED AND RETURNED TO THE CITY OF HARRISBURG
OFFICE OF THE CITY ENGINEER, 123 WALNUT STREET, SUITE 212, HARRISBURG, PA 17101-1695

STATION NAME:	PROJECT NUMBER:
----------------------	------------------------

GENERAL INFORMATION	
<i>Locality:</i> CITY OF HARRISBURG	<i>USGS Quad Name:</i>
<i>Established By:</i>	<i>Date Established:</i>
<i>Type of Mark:</i>	<i>Stamping:</i>
<i>Description:</i>	

SPECIFICATIONS	
<i>Horizontal Control Derived By:</i>	<i>Horizontal Order Accuracy:</i>
<i>Vertical Control Derived By:</i>	<i>Vertical Order Accuracy:</i>
<i>Horizontal Datum:</i> NAD83 / WGS84	<i>Vertical Datum:</i> NAVD88

NGS VERTICAL TIES	
<i>NGS Benchmarks that derived this station's original elevation:</i>	

GEODETTIC COORDINATES	
<i>Longitude:</i>	<i>Northing:</i>
<i>Latitude:</i>	<i>Easting:</i>

ELEVATION - NAVD88	
<i>Elevation (Meters)</i>	<i>Elevation (U.S. FT.):</i>

TO REACH DESCRIPTION	SKETCH
DESCRIPTION OF MARK	